

23

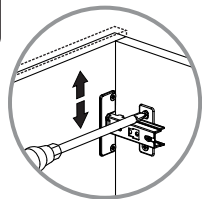

AJUSTE DE ALTURA
/ HEIGHT
ADJUSTMENT

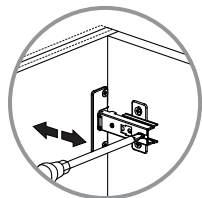

AJUSTE DE PROFUNDIDAD
/ DEPTH
ADJUSTMENT

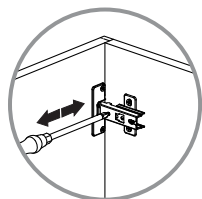

AJUSTE LATERAL
/ LATERAL
ADJUSTMENT



Al terminar de armar, desprenda los adhesivos (en caso de que queden residuos de pegamento, limpie la superficie con alcohol) / After finishing the assembly, take off the adhesives. (In case of glue residues, wipe them with alcohol)

Deslice los cajones dentro del mueble / Slide the drawers inside the cabinet

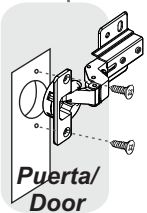
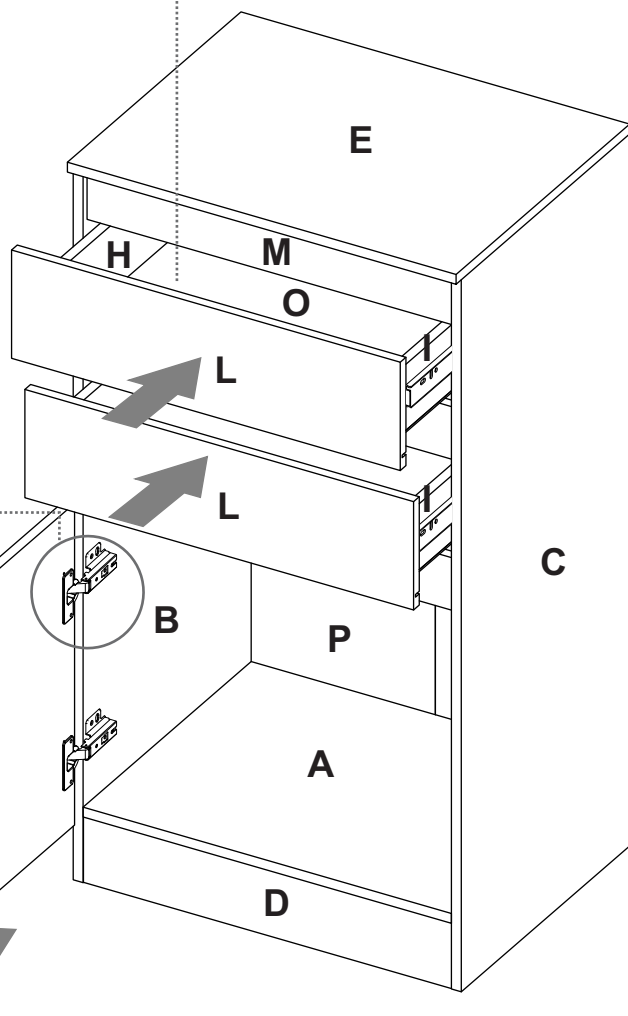

Puerta/ Door

Rta
design

INSTRUCCIONES DE ENSAMBLE
/ASSEMBLY INSTRUCTIONS

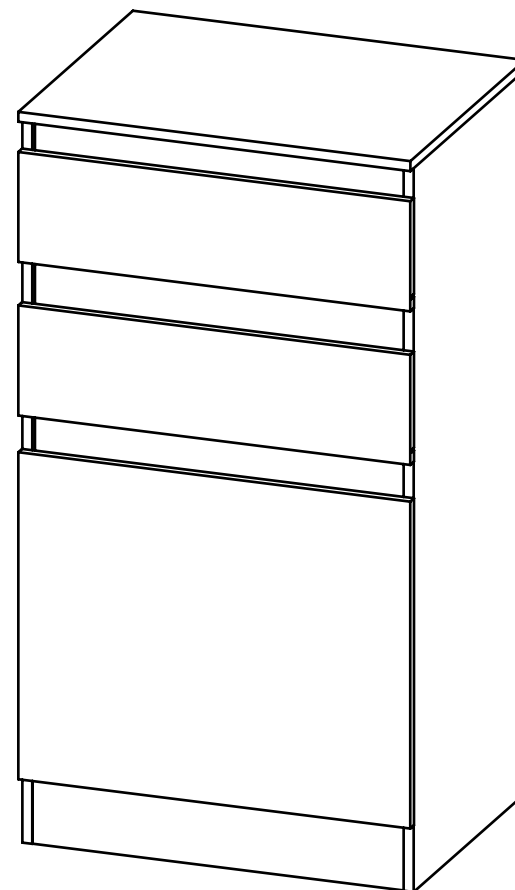

Alto/ Height: 110,7 cm / 43,6 in
Ancho/ Width: 59,2 cm / 23,3 in
Fondo/ Depth: 46,1 cm / 18,15 in

LOTE No: _____

REF./SKU. JWA 2902

By: **Rta**
design
RTA DESIGN S.A.S.
TEL (572) 691 17 00
PBX (572) 695 91 81
CALI - COLOMBIA
www.rta.com.co

JOYERO KAMELOT
/Kamelot Jewellery Cabinet

RECOMENDACIONES IMPORTANTES KEY RECOMMENDATIONS

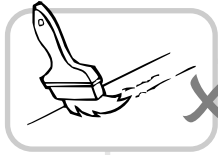

NO pinte el mueble /
Do not paint the
furniture.



NO mojar o ubicar
a la intemperie /
Do not expose to rain
or direct sun.

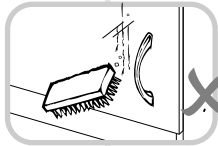
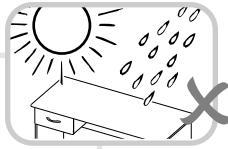

NO lavar las manijas o
tiraderas con jabones o
elementos abrasivos /
Do not wash handles or
drawers with soap or
abrasives.

NO sobrecargue el mueble.
no exceda el peso de 30 kilos
para gabinetes de cocina /
Do not overload the cabinet.
Weight max. 66lbs
for kitchen cabinets.

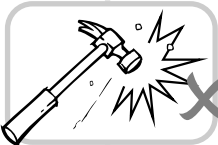

NO golpear ni martillar
el mueble (hágalo sólo
donde se indique) /
Do not hit or hammer
the furniture (just do it
where is indicated).

NO permita que los niños
manipulen el mueble, puede
voltearse y lastimarlos /
Do not allow children to
handle the cabinets or
drawers, they could get hurt.

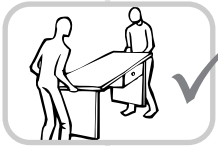
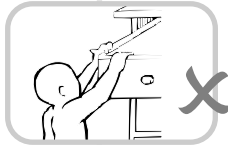

SIEMPRE levante el
mueble entre dos
personas, NO lo arrastre /
Do not drag the furniture.
Lift it between two people.

Limpie con paño seco,
/ Clean with a dry cloth.



HERRAJES BÁSICOS PARA MUEBLES RTA BASIC HARDWARE FOR RTA FURNITURE

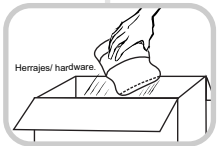

1. Abrir la caja del mueble
y buscar la bolsa con los
herrajes / Open the box
and look for the hardware
bag.

3. Separe los herrajes para
facilitar su identificación
durante el armado /
Separate hardware for easy
identification during
assembly.

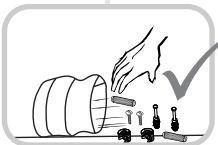
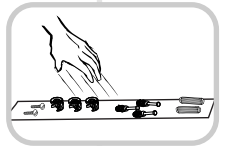

2. Abrir el paquete y
comprobar que el
contenido de las piezas es
correcto / Open the
package and verify that
the content of the pieces
is correct.

4. Arme el mueble en un
lugar limpio y en una
superficie plana / Assemble
the furniture in a clean
place and on a flat surface.

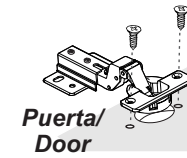
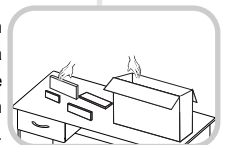

Puerta/
Door

Brazo Neumático
mini /
Neumatic arm

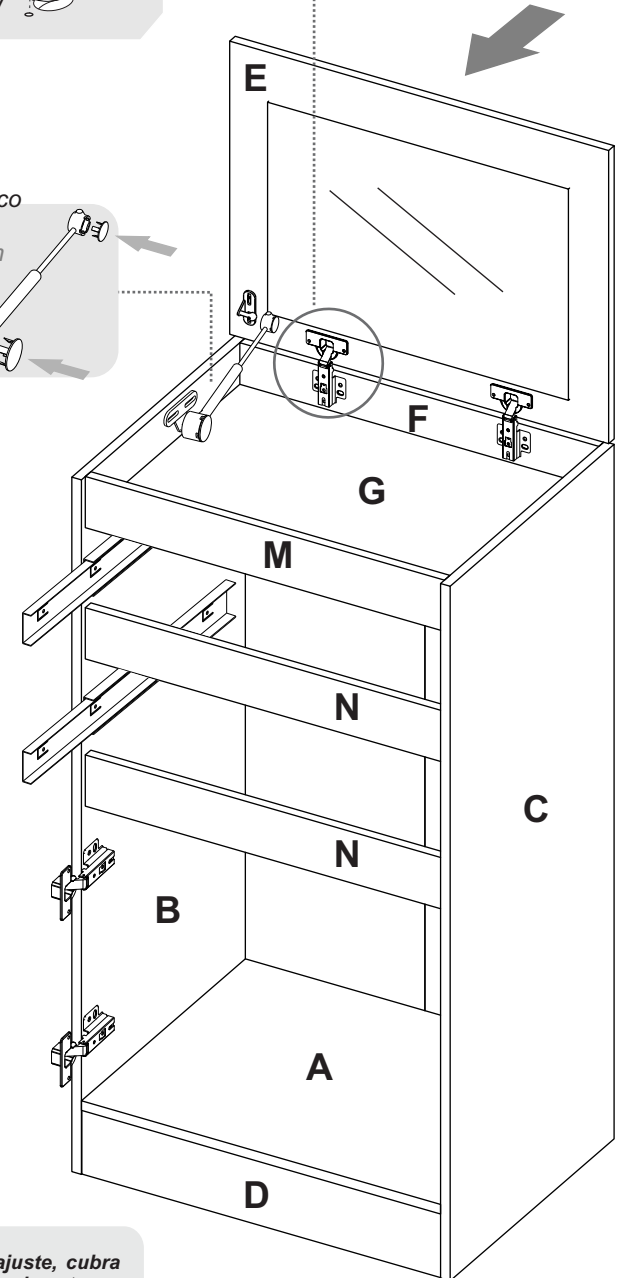
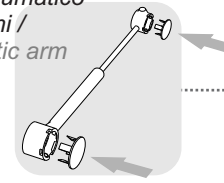

Al finalizar el ajuste, cubra
las cajas con las tapas
adhesivas/ After tightening all
the panels, cover the minifix
cams with the adhesive caps.

21

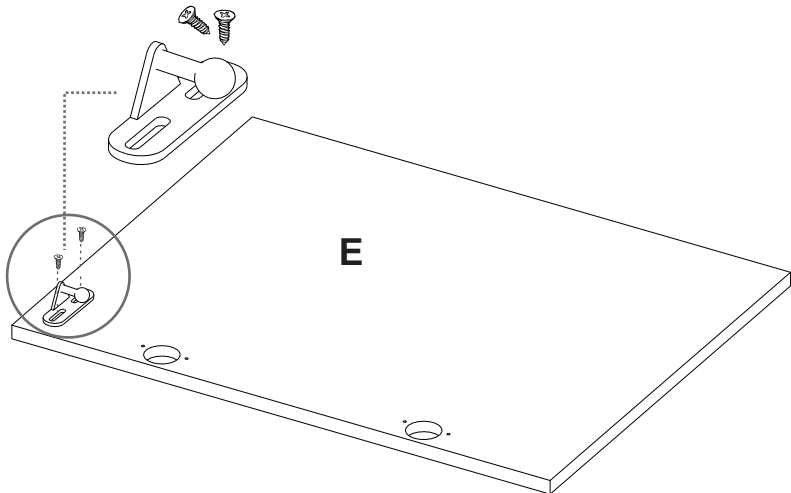

Limpiar bien la superficie y pegar el espejo sobre la pieza / Do a right cleaning of the surface, then place the mirror on the piece.

2

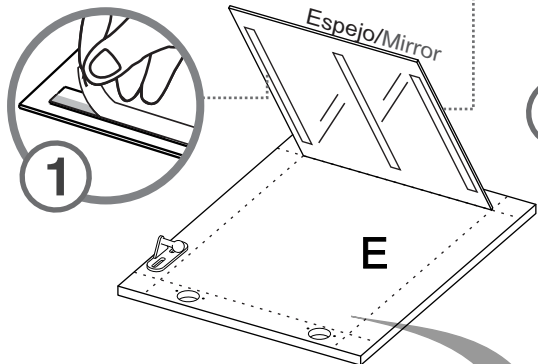

Hacer presión sobre el espejo y las cintas / Apply pressure on the mirror and tapes.

1

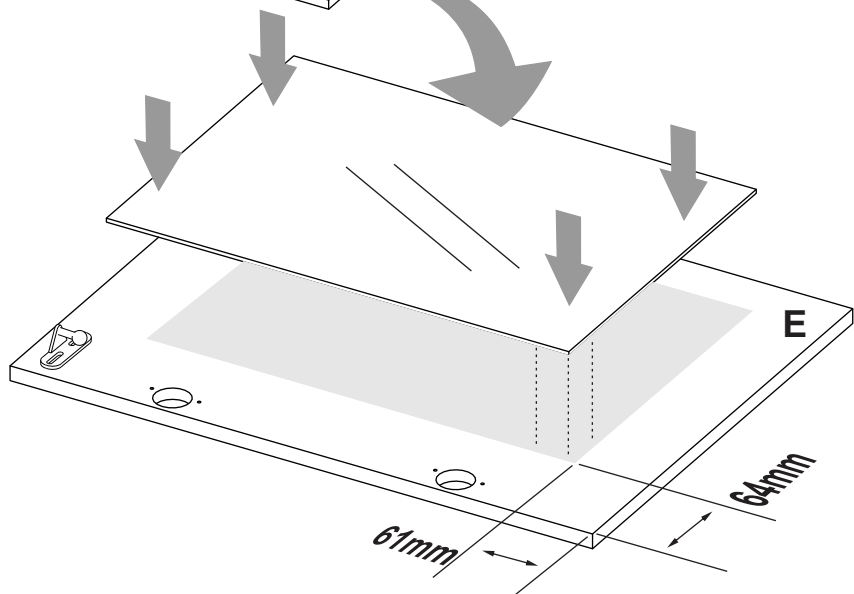

RECOMENDACIONES DE ENSAMBLE / ASSEMBLY RECOMMENDATIONS

El buen funcionamiento del mueble depende de un adecuado ensamblaje
An excellent furniture's performance relies on a solid and a suitable assembly.

MINIFIX / CONNECTOR - DOWELS

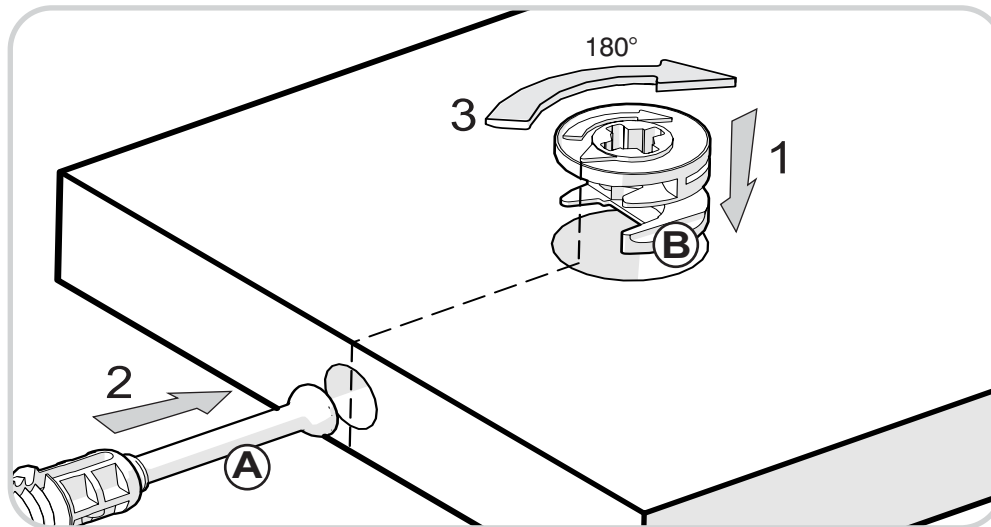

Sistema de unión compuesto por un perno (A) y una caja minifix (B).

(1) Se inserta la caja minifix dentro de la perforación ubicada en la cara de la pieza, la flecha debe apuntar siempre a la dirección de la perforación por donde entrará el perno.

(2) Se debe insertar el perno por su parte plástica en las perforaciones que se indiquen, luego se inserta la punta metálica en la perforación para que su cabeza quede al interior de la caja minifix.

(3) Girar la caja minifix 180° para apretar las dos piezas.

It's a fitting system made of a spreading bolt (A) and a minifix cam (B).

(1) Insert the minifix cam in the hole placed in the face of the panel with the arrow pointing towards the hole where the bolt will fit.

(2) Insert the bolt with its plastic base in the shown holes, then insert the metallic bolt head in the holes so it fits inside the minifix cam.

(3) Tight the panels by turning the minifix cam 180°.

TARUGOS O TAQUETES / FLUTED DOWEL PIN

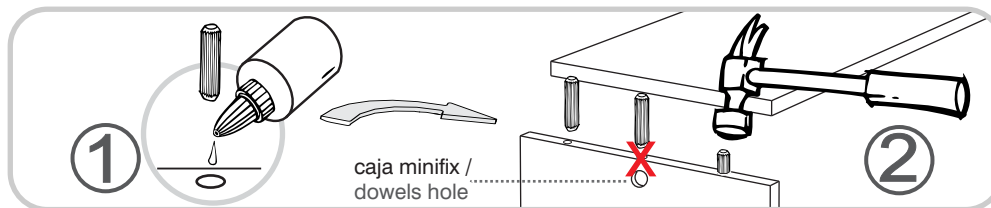

Es un pedazo de madera corto y grueso, de aproximadamente 5 a 10 cm de largo, que sirve para amarrar el mueble y darle resistencia. Tenga en cuenta que debe aplicar una gota de pegamento en cada perforación en la que se pondrá el taquete.

It's a short and thick piece of wood, 1,9 to 3,9 inches approximately, which is used to tie the cabinet and give it resistance. Take into account to apply a drop of glue on each hole you will insert the fluted dowel pin.

HERRAJES PARA ARMADO ASSEMBLY HARDWARE

x28



Tarugo/
Fluted dowel Pin

x21



Perno minifix/
Spreading Bolt

x21



Minifix/
Minifix Cams

x15



Tapa Adhesiva
Minifix/
Cover Caps

x6



Tapa Adhesiva
Tornillo/
Cover Caps

1/2"



Tornillo Ensamble
Drywall Screw

x4

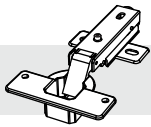

Bisagra
Parche 35mm/
Full Overlay Hinge

x1



Pegante/
Glue

x1

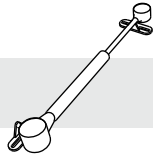

Brazo Neumático
mini /
Neumatic arm

x44



Tornillo lámina
6 X 9/16"/
Sheet Screw

x8



Tornillo
Ensamble 2"/
Drywall Screw

x18



Tornillo
Ensamble 1/2"/
Drywall Screw

x4



Deslizador
Puntilla/
Nail On Glide

x2

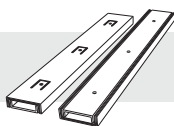

Riel extensión Total /
Full Extension Drawer
Slide

x18



Puntilla/
Panel Pin

x1

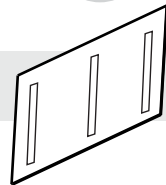

Espejo + Cinta/
Mirror + Double sided
tape stretches

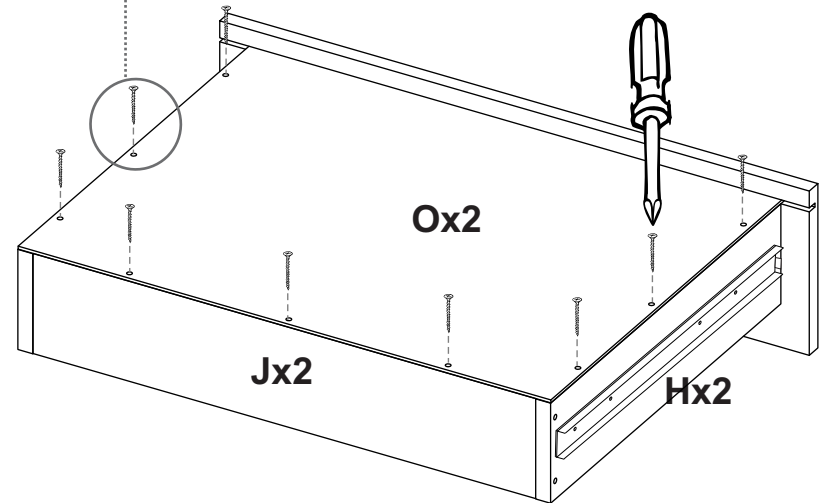

TENER PRECAUCIÓN AL ABRIR LA BOLSA DE HERRAJES PARA NO EXTRAIAR NINGUNO. COMPRUEBE QUE EL CONTENIDO DE LAS PIEZAS SEA EL CORRECTO. EN CASO QUE FALTE ALGUNA PIEZA O ESTE DEFECTUOSA DEVUELVA LAS PIEZAS AL ALMACÉN CON SU FACTURA PARA EFECTUAR EL CAMBIO DE LAS PIEZAS Y/O LOS HERRAJES LO MÁS PRONTO POSIBLE. / PLEASE BE CAUTIOUS WHEN OPENING THE HARDWARE BAG TO NOT LOSE ANY. CHECK THE CONTENTS OF THE PARTS ARE CORRECT. IF ANY PART IS MISSING OR IMPERFECT PLEASE RETURN THE PARTS TO THE STORE WITH THE PRODUCT INVOICE ATTACHED TO MAKE EFECTIVE THE REPLACEMENT OF THE IMPERFECT PIECES OR HARDWARE AS SOON AS POSSIBLE.

18

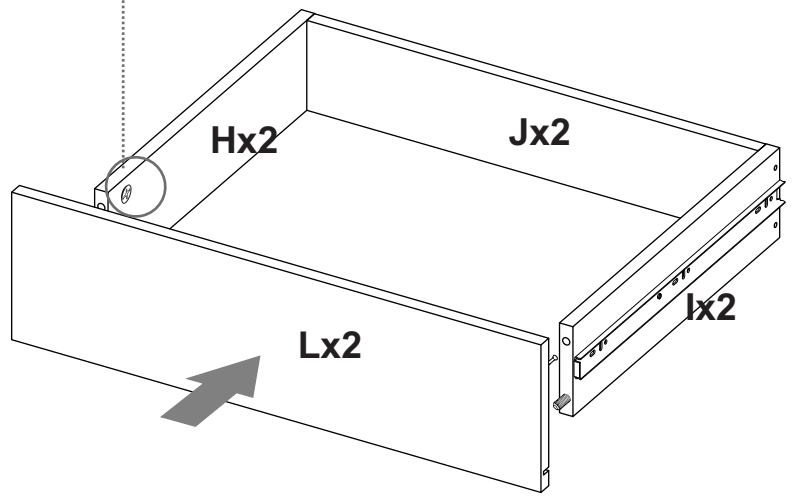
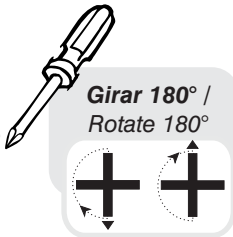

19

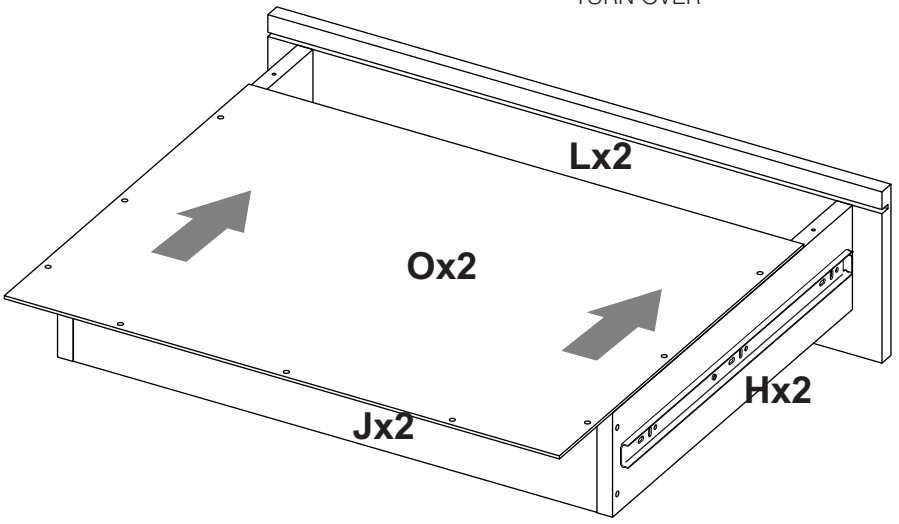

PIEZAS DE ARMADO
ASSEMBLY PARTS

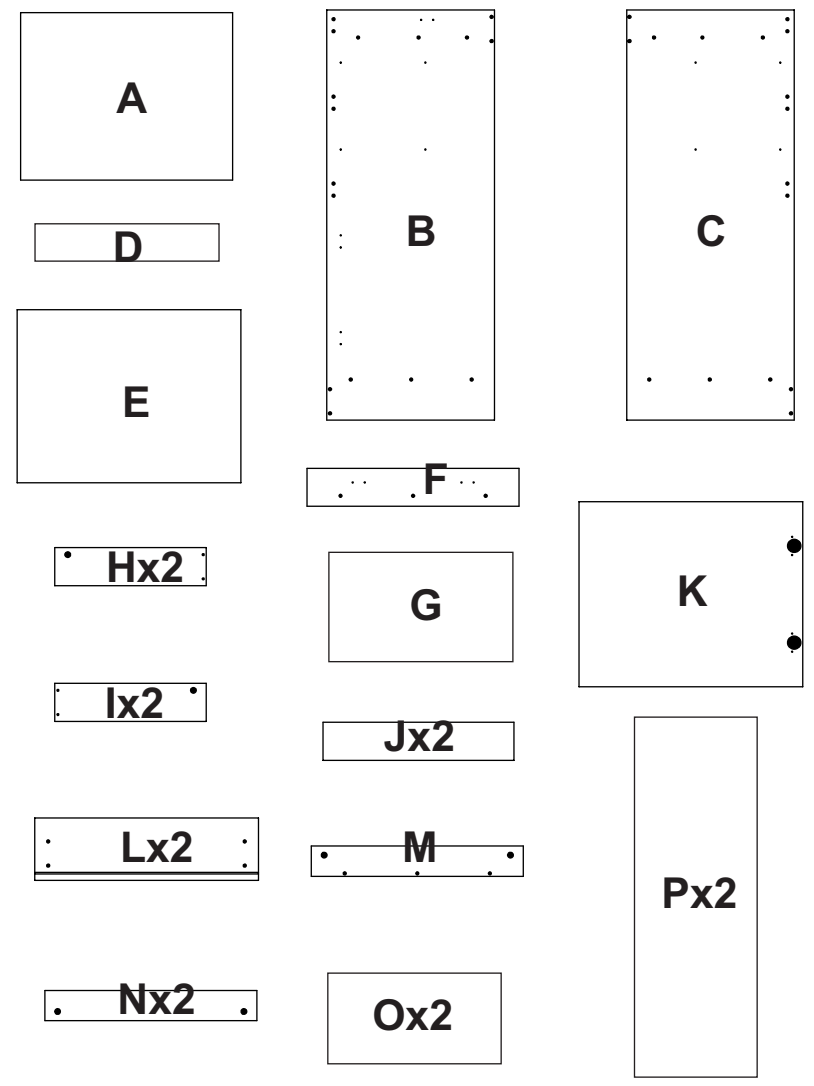

 ANTES DE EMPEZAR A ARMAR EL MUEBLE LEA DETENIDAMENTE LAS INSTRUCCIONES. SE RECOMIENDA ARMAR EL MUEBLE SOBRE LA CAJA O SOBRE UNA SUPERFICIE LISA Y CUBIERTA, PARA NO RAYARLO / BEFORE STARTING TO ASSEMBLE THE FURNITURE, CAREFULLY READ THE INSTRUCTIONS. IT IS RECOMMENDED TO ASSEMBLE THE FURNITURE ON THE BOX OR ON A FLAT AND COVERED SURFACE IN ORDER TO NOT SCRATCH THE PRODUCT.

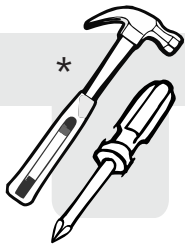

*

*(Herramientas NO incluidas) *Tools NOT Included

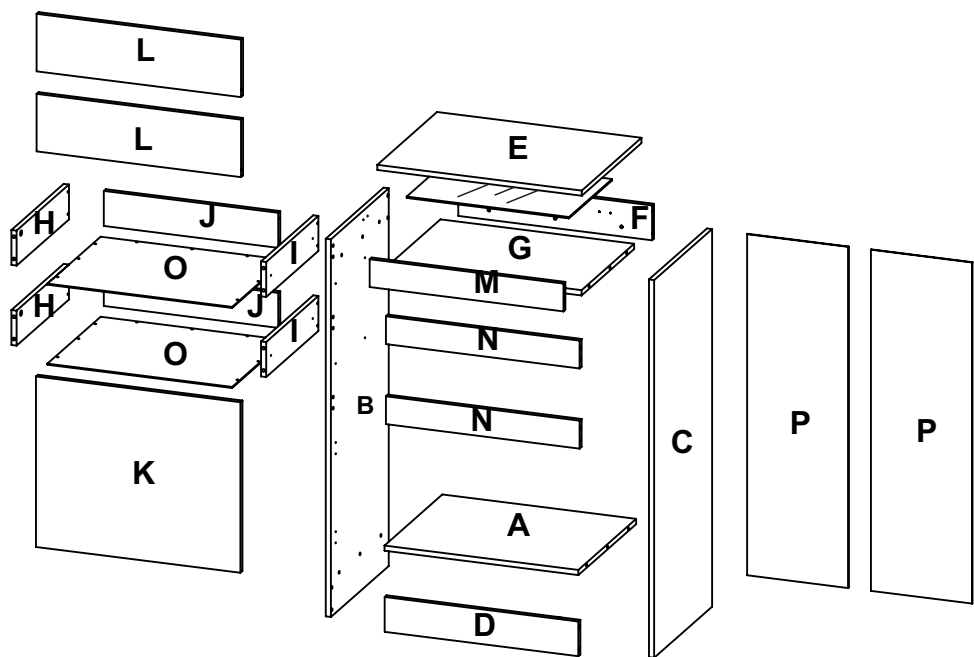

16

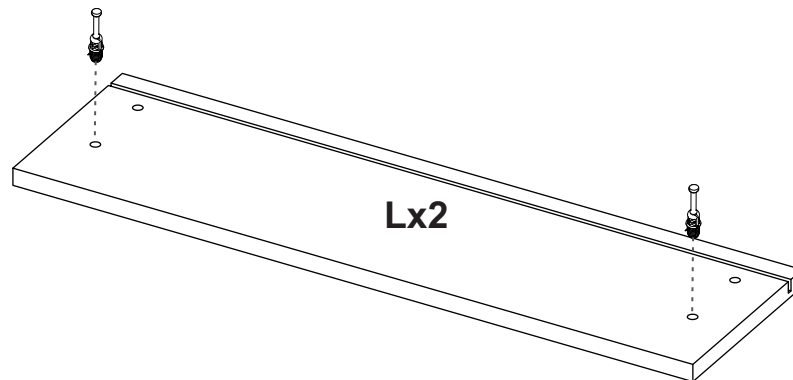

17

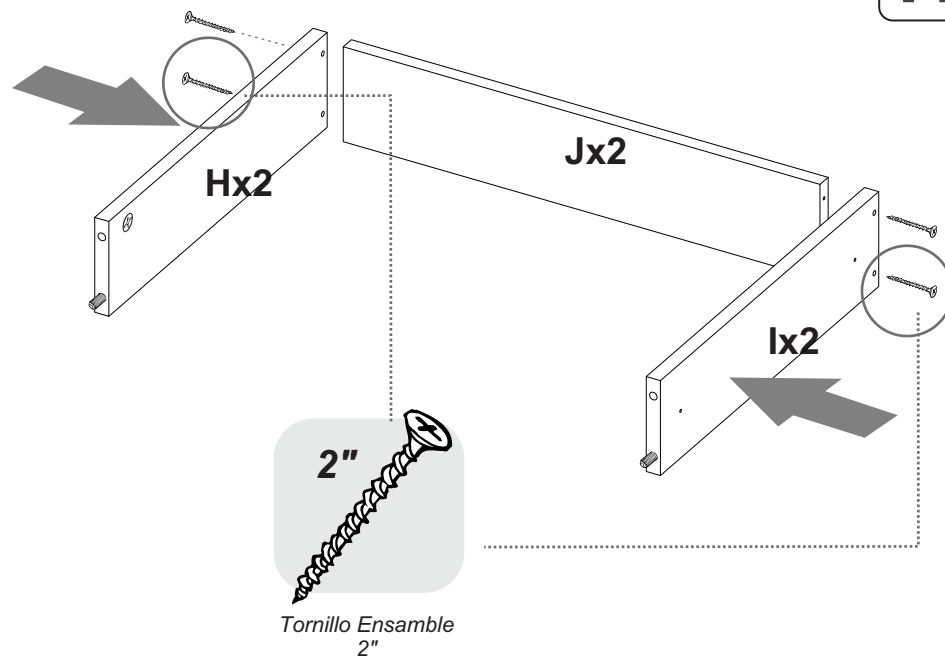

14



**PARA PONER RIEL EN LATERAL DEL CAJÓN/
When placing the slide on the side of the drawer:**
Revisar que el **tope metálico** del riel quede en la **PARTE DELANTERA**/
The metallic stop should be placed on the front.

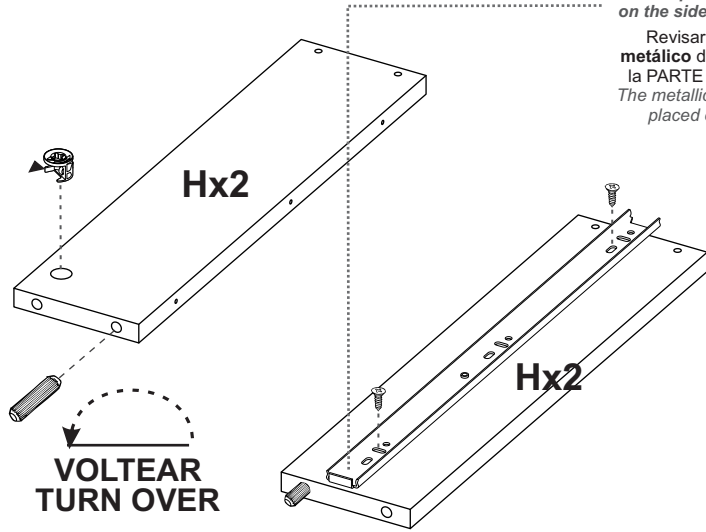

**SE RECOMIENDA ARMAR EL MUEBLE ENTRE DOS PERSONAS /
IT IS RECOMMENDED TO ASSEMBLE THE PRODUCT BETWEEN TWO PEOPLE**

1

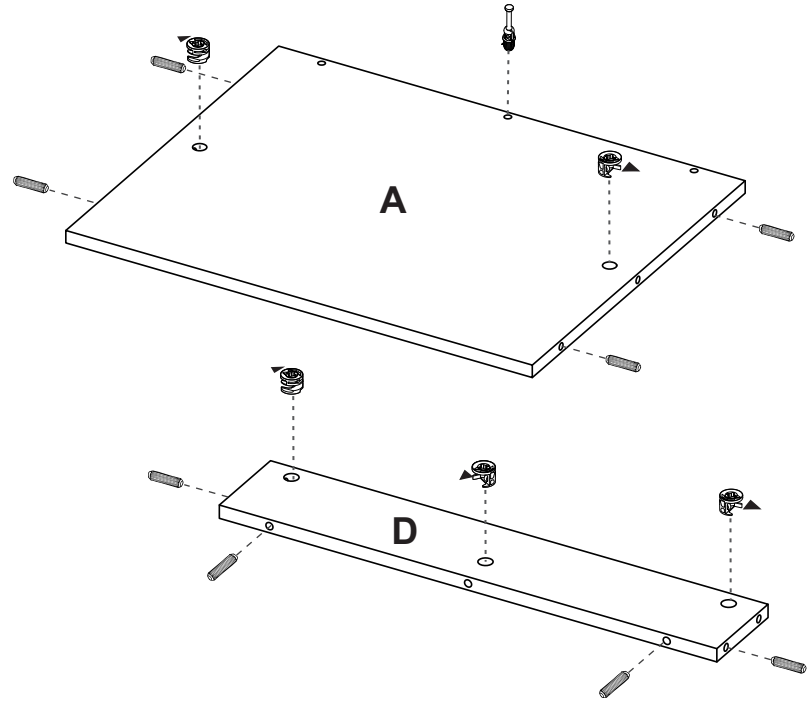

15



**PARA PONER RIEL EN LATERAL DEL CAJÓN/
When placing the slide on the side of the drawer:**
Revisar que el **tope metálico** del riel quede en la **PARTE DELANTERA**/
The metallic stop should be placed on the front.

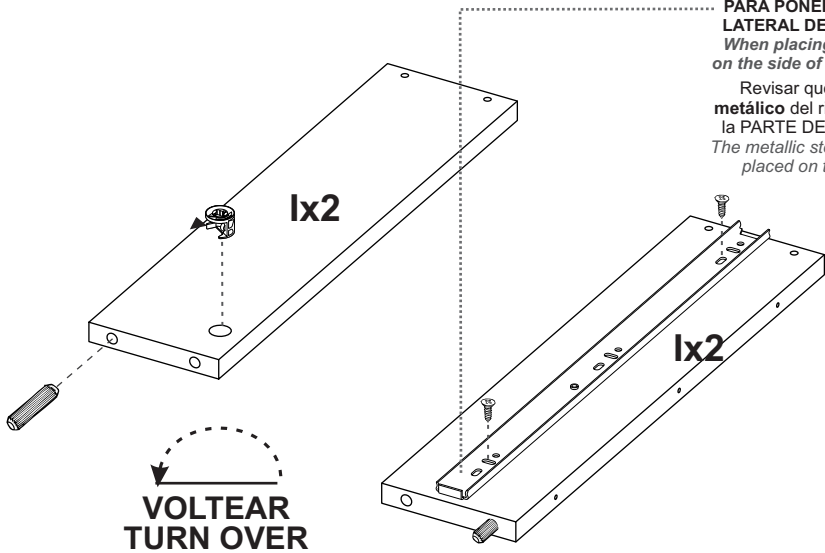

2

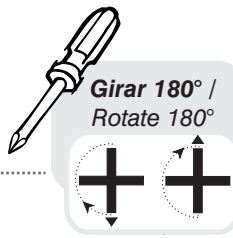
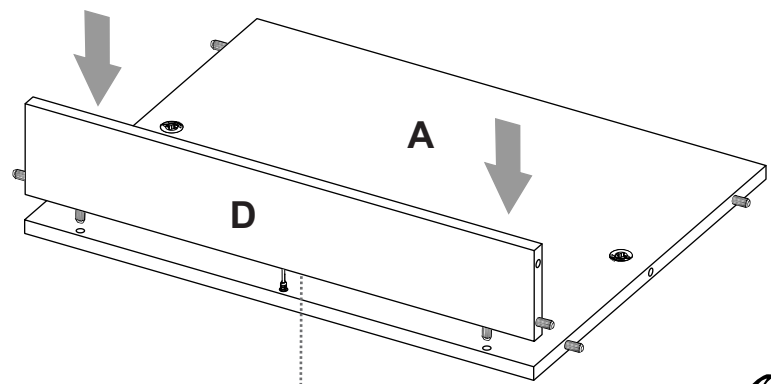

3

**VOLTEAR
TURN OVER**

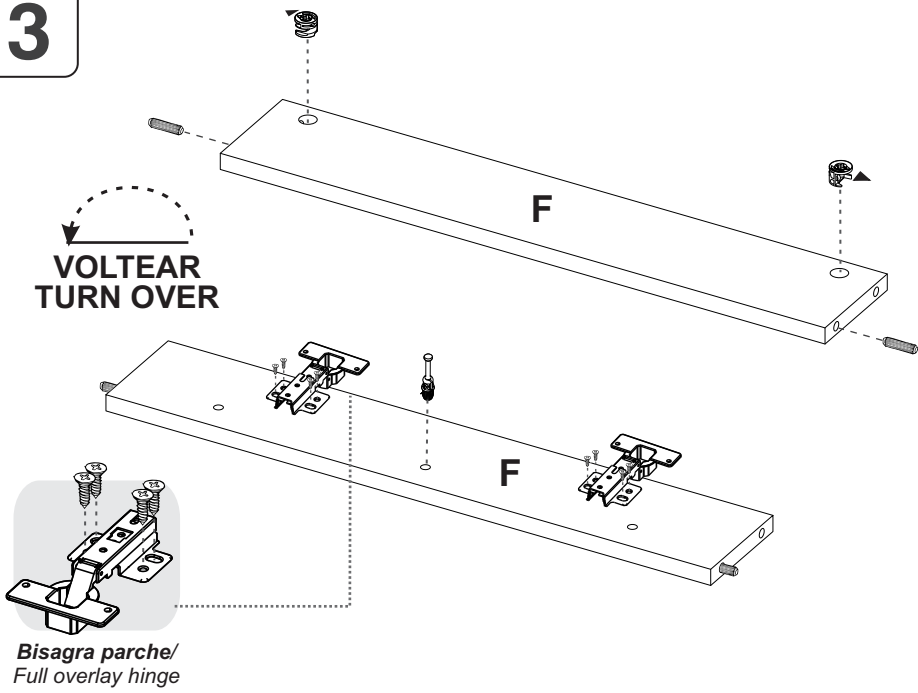

4

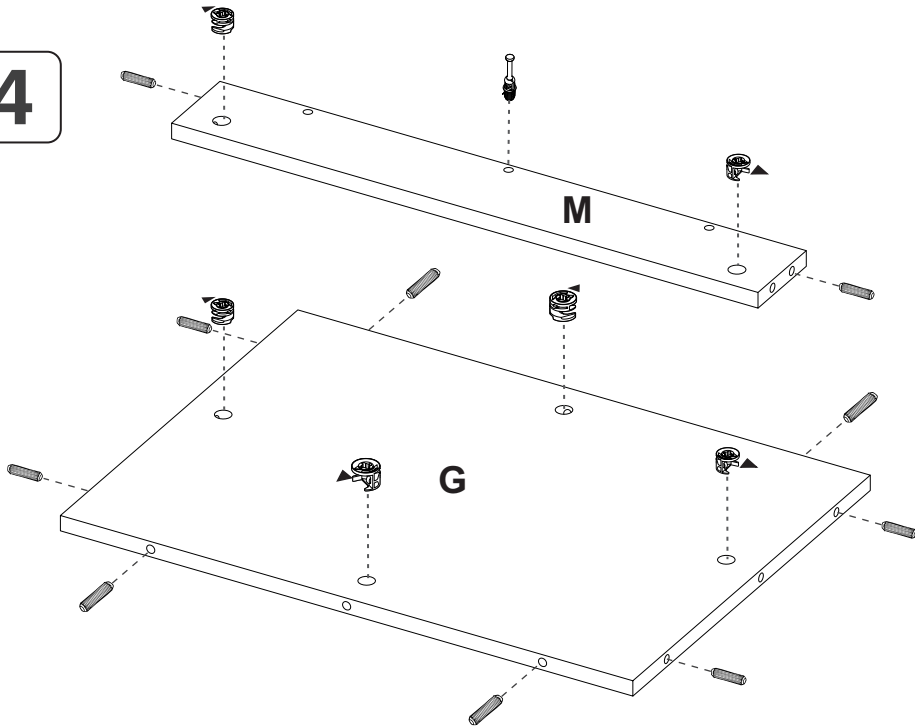

13

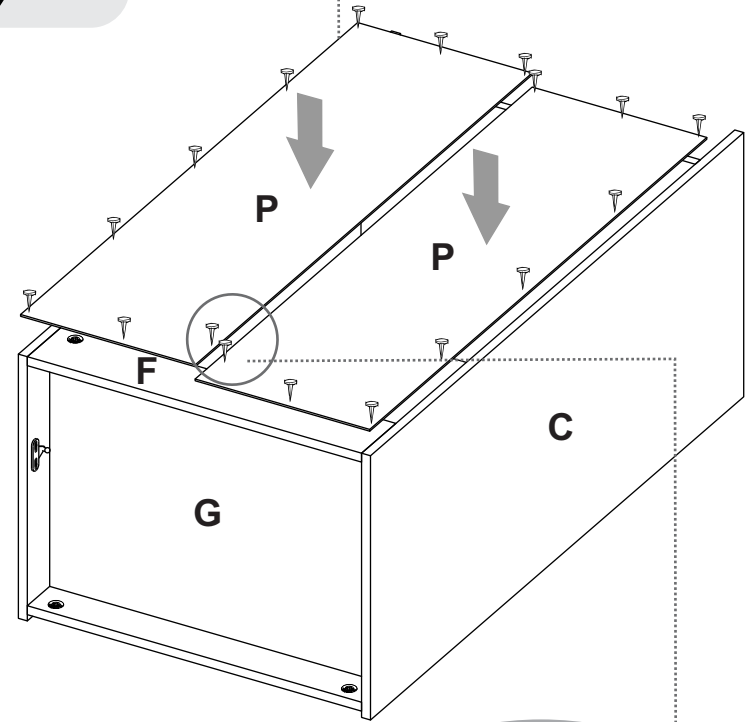

**VOLTEAR EL MUEBLE CUIDADOSAMENTE
/ CAREFULLY FLIP THE CABINET**

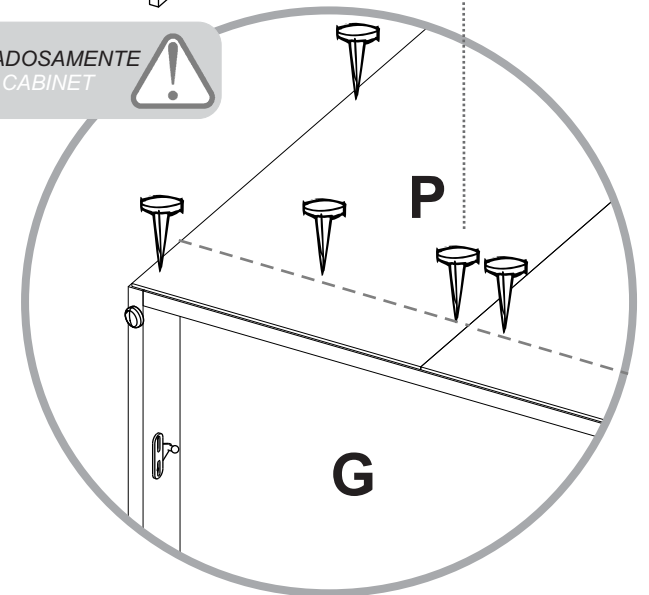

11

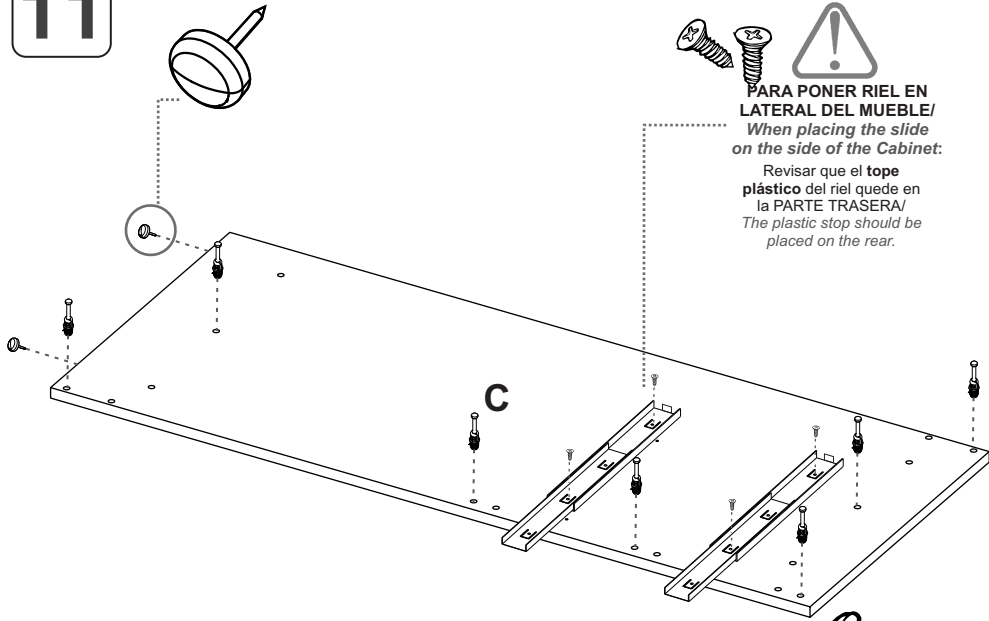

12

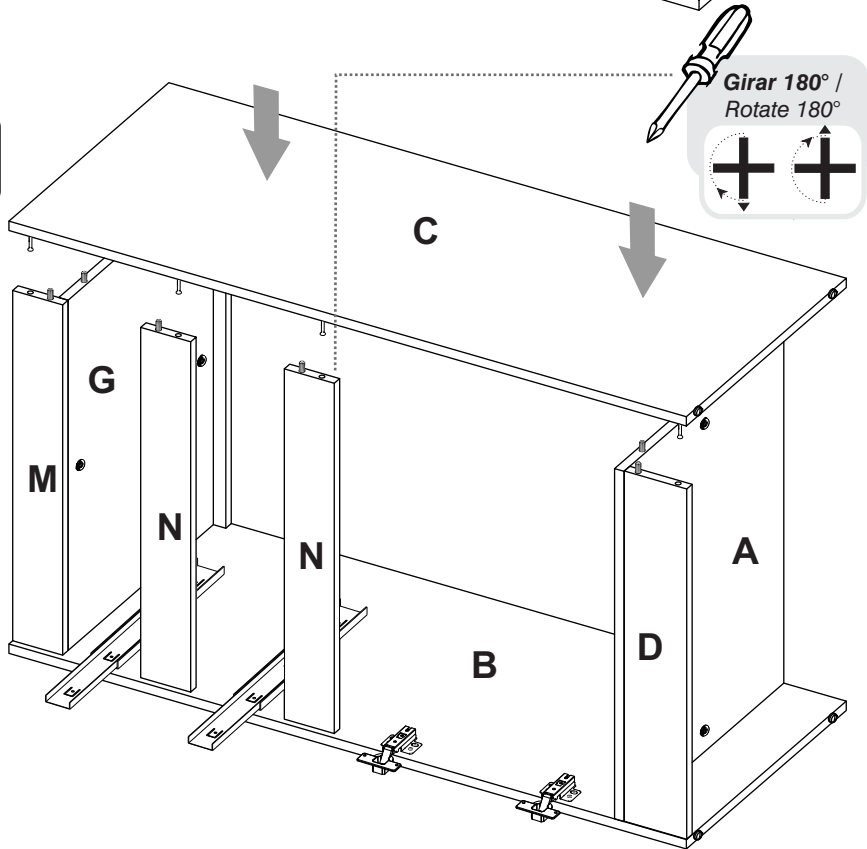

5

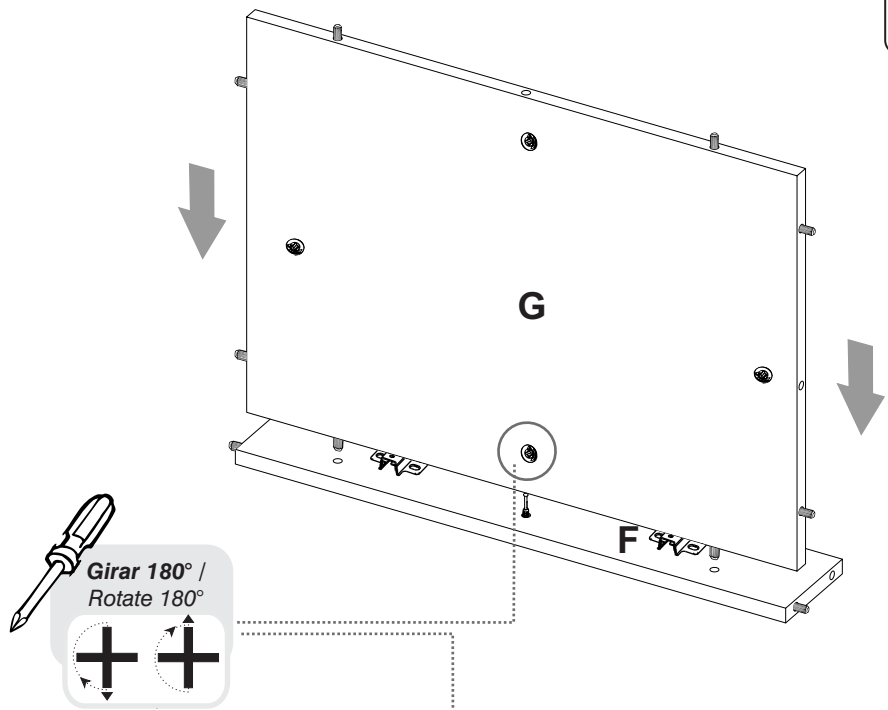

6

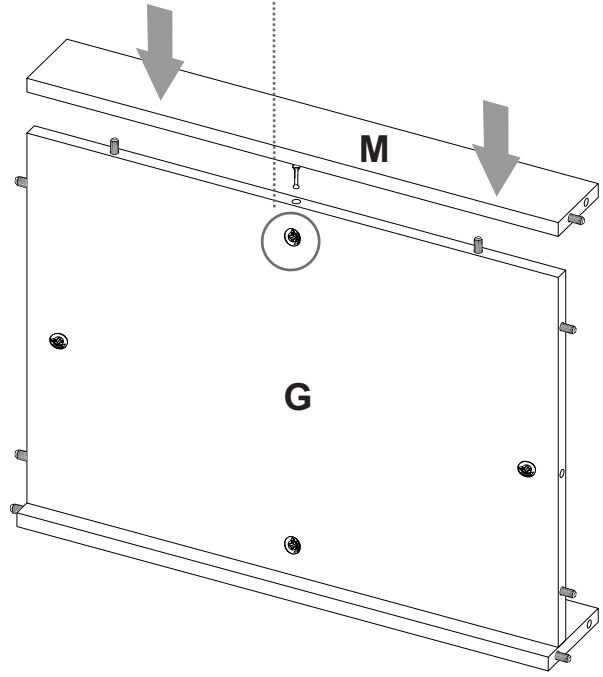

7

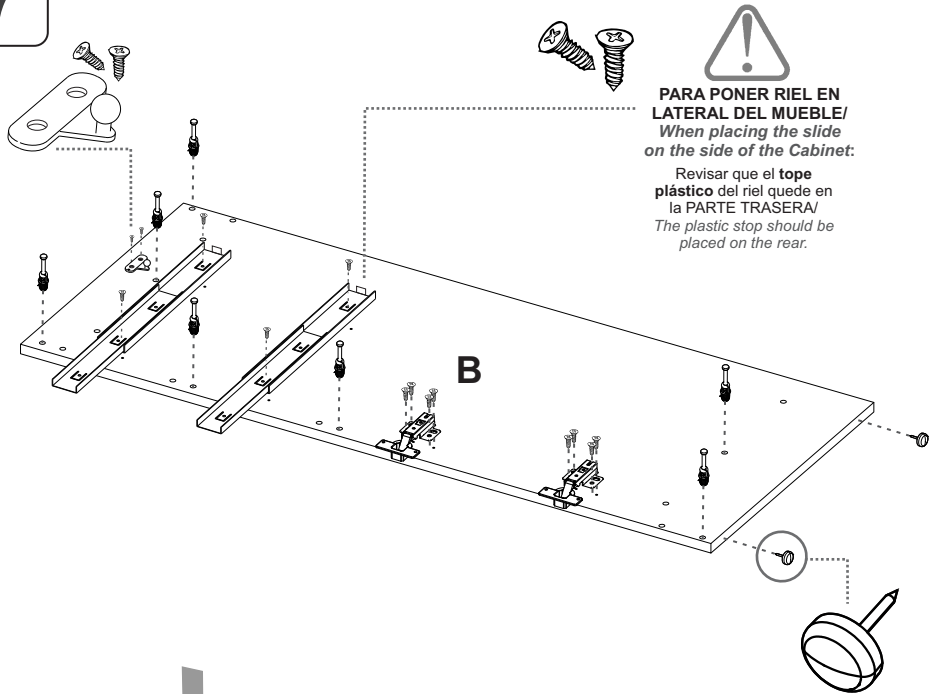

8

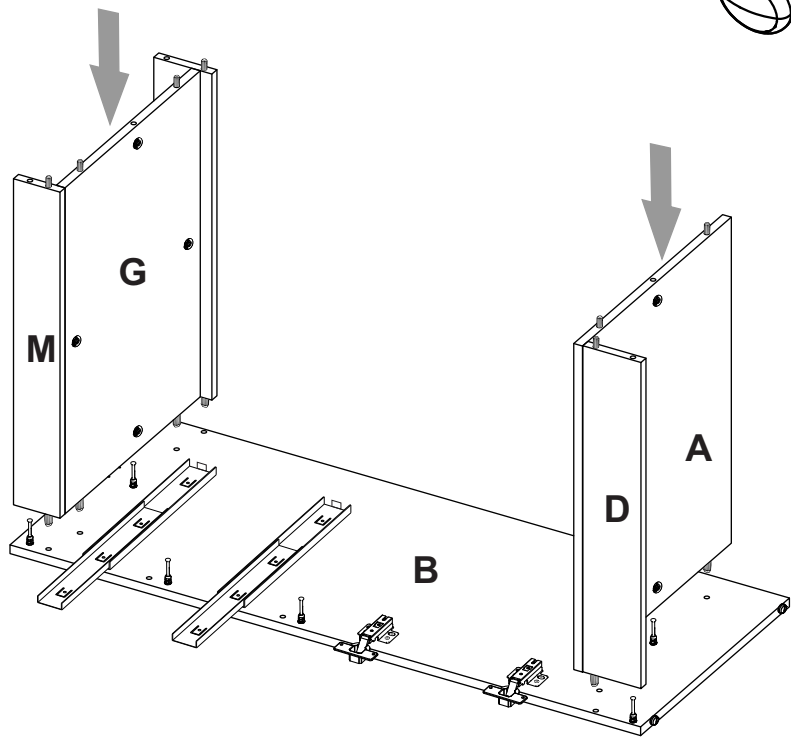

9

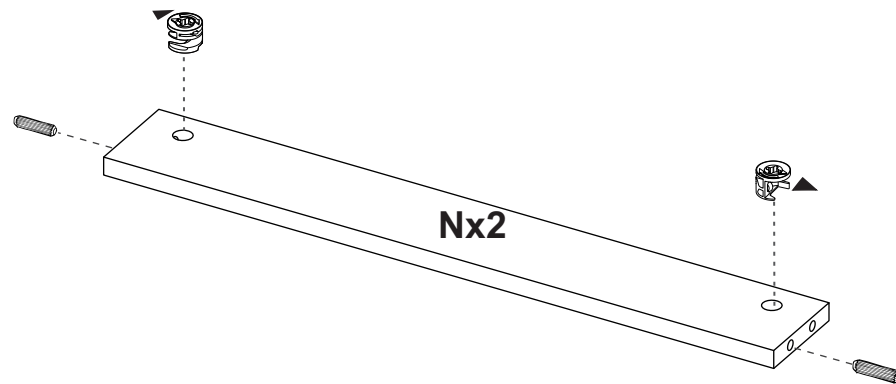

10

